

# CS118-M Subwoofer



## Applications

Performing Arts Centers  
Houses of Worship  
Arenas/Auditoriums  
Night Clubs  
Cruise Ship Venues  
A/V Systems Support

## Features

Max Output 133 dB SPL  
10° Trapezoidal Arrayable Cabinet  
LF Device: (1) 18 in (457.2mm)  
Integral Bimodal Rigging  
Black Epoxy Mastic Finish  
(2) EP-4 Connectors

## General Description

The CS118-M is the mobile low frequency subwoofer extension of the Clair Brothers C Series line array systems designed for mobile applications. This arrayable subwoofer is specifically designed to complement the C8-M and C12-M mobile line array systems.

The 18in. direct radiating transducer has a weather-resilient cone that produces exceptional linear excursion, and maximum peak to peak excursion of 70mm (2.75 in). The result is a high power handling, high performance subwoofer that delivers tightly controlled low-frequency response.

The CS118-M has a three-point integral bimodal rigging system for various configurations. The cabinet may be flown above the C8-M line array, providing an aesthetically pleasing alternative to ground stacked subs beneath the array. The CS118-M may also be flown alongside the C12-M array as a bass array.

For applications where flown rigging is not possible, the CS118-M can serve as a ground stacking base for the C8-M line array speakers.

As with all Clair Brothers speaker products, the CS118-M is constructed with the finest Baltic birch plywood and finished with a rugged exterior black epoxy mastic finish to withstand the most demanding conditions.

## Options & Accessories

CS118-M – Mobile Model

CS118-i – Installation Model

Ground Stack Rigging | Soft Cover | Transport Dolly

Custom Rigging

Custom Colors Available

## Companion Line Array Systems

C8-M – Mobile Model | CS118 rigs above

C12-M – Mobile Model | CS118 alongside

# CS118-M Subwoofer



## Audio Specifications

Loudspeaker Type		Arrayable Subwoofer
Frequency Response	Single Cabinet	34Hz–180Hz (+/- 2dB)   (-10dB Point) 30Hz
Recommended Power Amplifier		CB-PLM12K44 or CB-D80:4L
Compatible Array Products		C8-M (sub rigs above), C12-M (sub alongside)
Prediction Software		Clair GLL/AFMG Ease Focus™ Array
Processing, Configuration & System Optimization Software		Lake Controller® with Clair DSP, WiFi System Control
Sensitivity (1 Watt @ 1 Meter)		97 dB SPL
Maximum Output <sup>1</sup>	Peak	133 dB SPL
Driver	LF	(1) 18 in. (457.2mm)
Nominal Impedance	LF	8 Ohms
Power Handling	Nominal	2000W
	Peak	4000W
Input Connection	Standard	(2) EP-4 Connectors (1 Male, 1 Female)

## Mechanical Specifications

Enclosure	Shell	18mm Baltic Birch
	Finish	Black Epoxy Mastic
Grille		Perforated Steel with Tension Mechanism, Foam Backed
Dimensions	Front Height	20.24 in. (514.0mm)
	Rear Height	15.49 in. (393.4mm)
	Width	28.87 in. (733.2mm)
	Depth	30.39 in. (771.9mm)
Weight		141 lbs. (63.9kg)
Shipping Weight		159 lbs. (72.1kg)

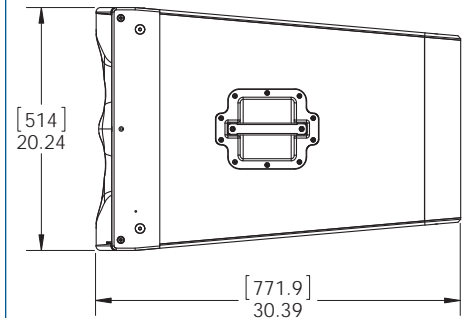
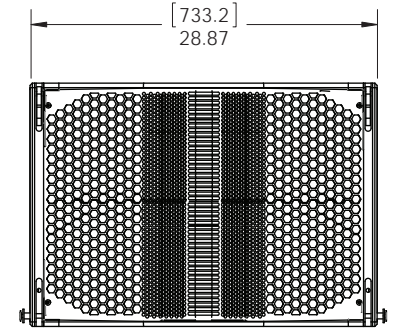

1) Measured @ 1 meter in free space with 12dB crest factor pink noise, unweighted.

Note: All wattage figures are calculated using the rated nominal impedance.

Clair Brothers products are designed to perform optimally by utilizing factory recommended proprietary DSP settings.

## Architect and Engineer Specifications

The loudspeaker shall be a mobile subwoofer system containing (1) 18" driver in a vented enclosure. Power handling capacity shall be 2000 watts RMS nominal and 4000 watts RMS peak. The low frequency driver shall be 18" diameter capable of handling 2000 watts of pink noise with a 6 dB crest factor for 8 hours (as per EIA RS-426-A standard). The pass-band frequency range shall be at minimum, 34–180Hz with -10dB at 30Hz. The 18" transducer shall have a 5.3" (135mm) diameter dual-layer aluminum ribbon voice coil with a low-noise, forced ventilation magnet structure. The motor assembly shall have high thermal capacity and low thermal power compression characteristics. The enclosure shall be constructed of 18mm, 13-ply Baltic birch and be covered with a black epoxy mastic finish. The cabinet bracing shall be that of a gusset design providing uniform panel rigidity. The rigging system shall consist of C8/C12 compatible integrated rigging with provisions for both hanging and ground stacked applications. Dimensions shall be 20.24" high, 28.87" wide, and 30.39" deep. The system weight shall be 141 lbs (63.9kg). The loudspeaker system shall be the Clair Brothers CS118-M speaker.

Due to constant research, development and improvements all specifications are subject to change without notice.

CBAS20171018