

# GENELEC®

**8331A**  
Smart Active Monitor

Operating Manual  
操作手册



## Introduction

Thank you for choosing a Genelec product! Fulfilling dreams by offering people the most truthful sound reproduction possible has been the source of our enthusiasm since 1978. There's already over one million Genelec monitors around the world - welcome to our story!

All Genelec monitors are designed, hand assembled and tested at our factory in Iisalmi, Finland. Our monitors are designed to last for decades and we take care that our customers receive excellent support and technical services throughout the life-time of the products.

Please register your monitor at <http://www.community.genelec.com/>. You will receive an extended 5 year warranty for spare parts. For more information about our service and technical support see

<http://www.genelec.com/customer-service>.

## System Characteristics

Each 8331A is supplied with one mains power cable, one 5-meter GLM network cable and this operating manual.

The Genelec 8331A is suitable for professional monitoring applications calling for very high precision and reliability. It combines many remarkable Genelec technologies to provide point source benefits with directivity control over an extraordinarily wide audio bandwidth.

### Genelec Loudspeaker Manager™ (GLM™) Software And GLM User Kit

The GLM software gets the most out of 8341 and tailor-fits it to your room. GLM is available for download free of charge at [www.genelec.com/glm](http://www.genelec.com/glm). Check in from time to time to take advantage of new features, or consider using the cloud-based version. A GLM User Kit comprising the necessary hardware, including the GLM Adapter and measuring microphone is needed for building and operating the GLM network. This kit can be purchased at all certified Genelec dealers.

### Minimum Diffraction Coaxial (MDC™)

The minimum diffraction coaxial driver is comprised of a powerful midrange driver combined with a tweeter driver extending to ultrasonic frequencies. This unique arrangement eliminates or minimizes acoustic diffraction sources that typically exist in coaxial drivers and produces a flat frequency response both on the acoustical axis and at all off-axis directions.

The 8331 may be oriented either horizontally or vertically and is intended for near-field listening where the influences of the room can be mostly minimized. Typical distances can vary from 1 meter or less to 3 meters depending on room size and SPL requirements.

### Directivity Control Waveguide (DCW™)

The 8331A has an unusually large directivity control waveguide extending over the whole front face of the enclosure. The midrange driver cone also forms a part of the directivity control waveguide for the tweeter. From behind the waveguide, two woofers radiate audio through two openings in the enclosure front. This unique design enables directivity control of all audio frequencies down to low bass.

## Acoustically Concealed Woofers (ACW™)

A pair of nearly invisible woofers in the 8331A are placed acoustically coaxially with the midrange/tweeter drivers to create a three-way system with all drivers having their acoustical axes in the same position. This creates an ideally working point source radiator.

### Smart Active Monitor (SAM™)

Genelec SAM technology can improve the reliability and accuracy of monitoring. Smart Active Monitors have several parametric notch and shelving filters that can be tuned automatically using the Genelec Loudspeaker Manager (GLM) software to exactly compensate for colorations generated by room acoustics. This enables SAM monitors to sound neutral and achieve accurate stereo imaging in all acoustical environments.

## Audio Inputs

The 8331A's audio inputs are designed to integrate easily into all professional environments, supporting balanced line analog and AES/EBU format digital signal. The maximum analog input level is +25 dBu (13.7 Vrms or 19.5 V peak). Set to the maximum sensitivity, an analog input signal of -6 dBu produces 100 dB SPL sound level at 1 meter in free space. A -30 dBFS digital audio input level produces 100 dB SPL level at 1 meter in free space. Note that 0 dBFS refers to the largest possible digital input value.

The XLR audio input accepts both AES/EBU format digital signal and analog line level analog audio signal. With an extremely low level AES/EBU signal, the automatic selection may not work properly. In such case, the signal selection can be made in the GLM software or, if GLM is not available, by setting the "Stored" DIP switch to "OFF" and selecting the appropriate AES/EBU channel with the "Digital" switches .

When using a digital audio source with adjustable level, it may instead be advantageous to lower the output level of the 8331A using the monitors on-board rear panel controls. This enables the use of a higher source output level with more digital resolution, while taking full advantage of 8331's impressively low self generated noise.

The AES/EBU format supports two channels of audio in a single cable. The DIGITAL OUT male XLR connector carries an unaltered copy of the digital input signal. This enables daisy-chaining of up to four monitors. The proper digital channel can be selected using DIP switches or GLM.

## Power Management

The 8331A mains power input supports any mains voltage globally (100-240 VAC, 50-60 Hz). It can be plugged in anywhere in the world and will always deliver the maximum output power to the drivers even when the mains voltage fluctuates. If mains power is provided with a generator, inverter or lower-quality UPS device, we recommend filtering out harmonics from the mains power voltage.

The energy saving function Intelligent Signal Sensing (ISS™) puts the monitor automatically into a deep sleep state when no input signal is present. The device then consumes less than one watt of power. Upon sensing an input signal, the monitor automatically awakens. The wait time until entering the power saving state can be configured using the GLM software. When ISS is active, you can leave your monitors on at all times and

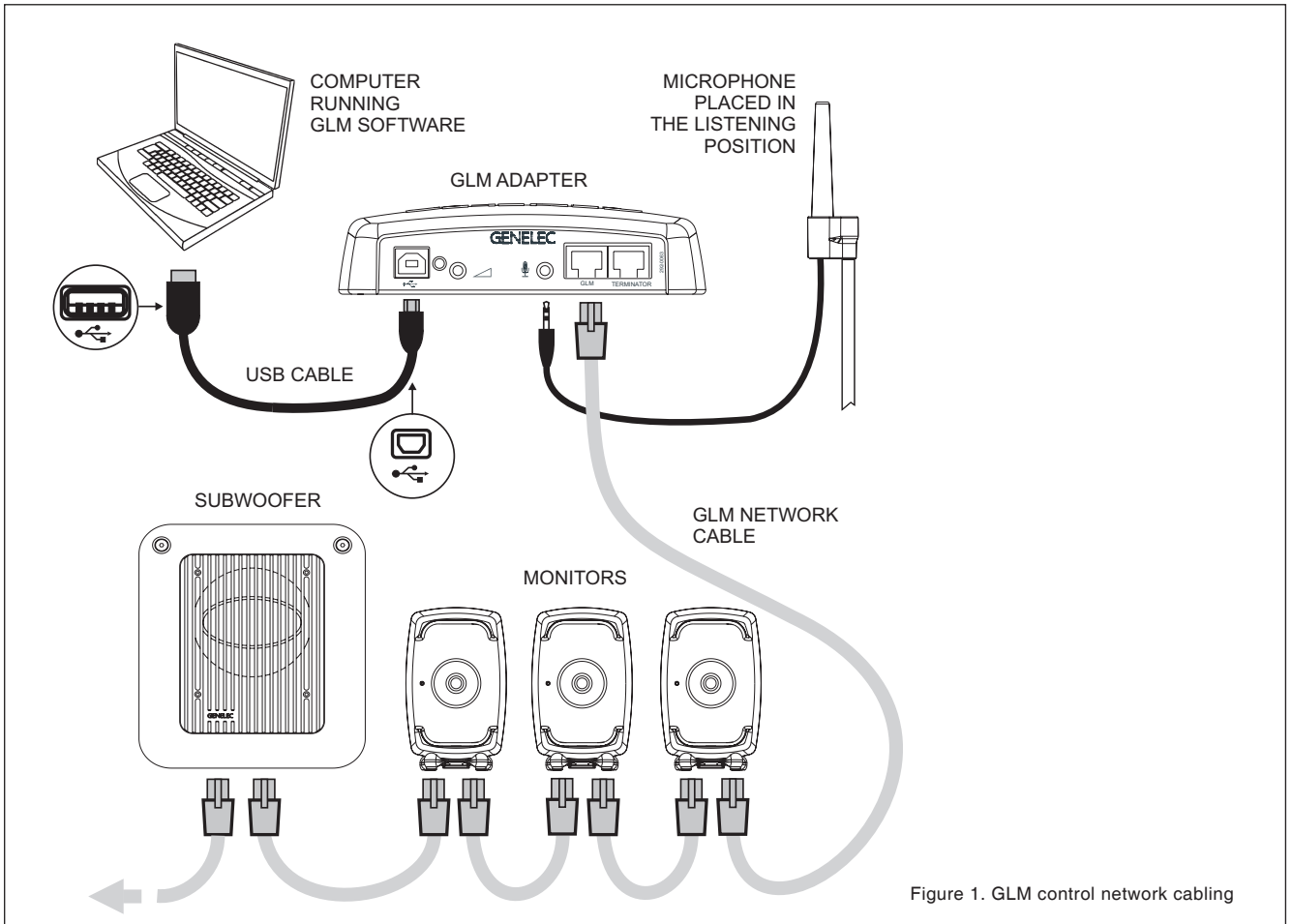

Figure 1. GLM control network cabling

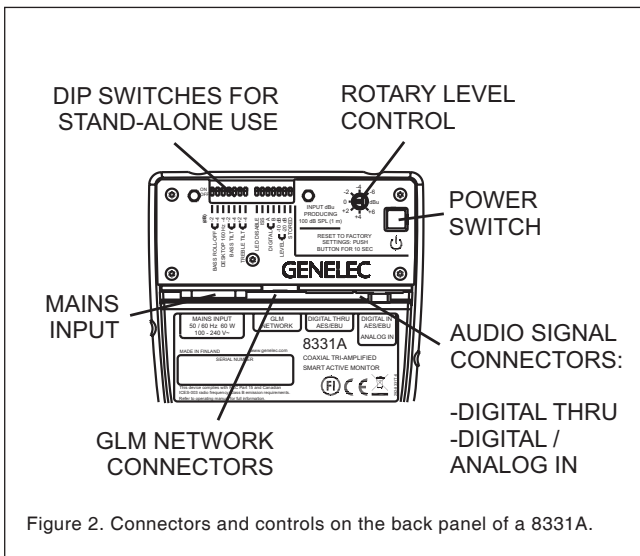

Figure 2. Connectors and controls on the back panel of a 8331A.

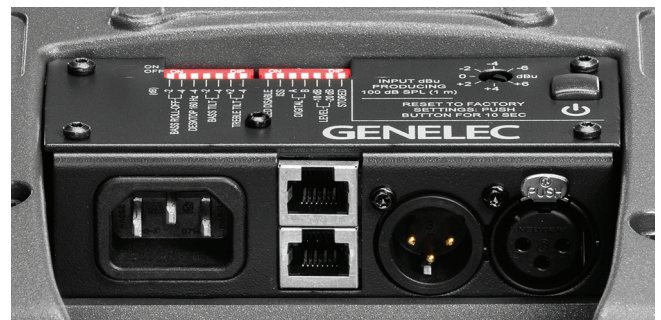

Figure 3. Connector panel detail.

have the monitoring system immediately ready for action. The default wait time when ISS is enabled using the ISS DIP switch is 60 minutes.

## Setup Using The GLM™ Control Network

Although the 8331A can be used without the GLM software and control network, it can only reach its full potential when set up and calibrated using GLM software, running on a Mac or PC.

Genelec therefore recommends setting up the 8331A

and other SAM monitors using GLM. You can find a detailed description of the setup and the use in the GLM System Operating Manual.

The GLM software and the proprietary Genelec monitor control network offer automated acoustic equalization and alignment for any reproduction system from mono over stereo to complex 3D immersive audio setups, including also one or more subwoofers. GLM includes AutoCal, an expert algorithm built on data from thousands of professional listening rooms.

Setup with the GLM User Kit consists of the following steps:

1. Connect a CAT5 (RJ45) cable between each monitor (and subwoofer) and finally to the control network input of the GLM Adapter device (see Figure 1).
2. Connect the GLM Adapter to computer USB connector.
3. Using a microphone stand, place the Genelec measurement microphone at the listening location with the microphone pointing upwards and the microphone top at the height of

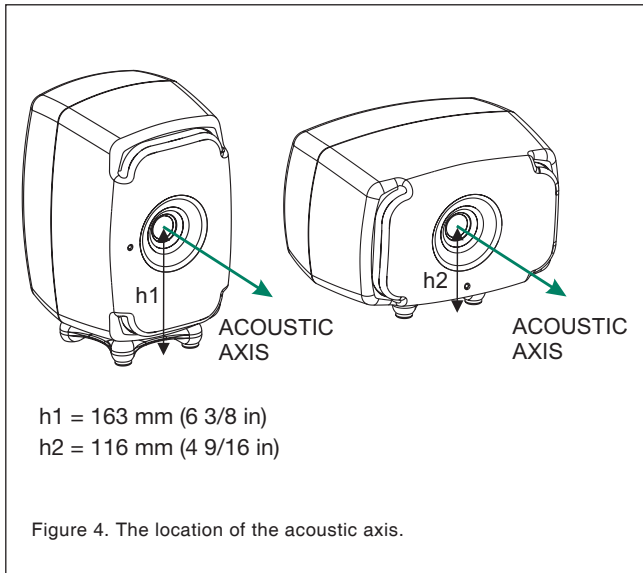

the engineer's ear. The microphone is a part of the GLM User Kit.

4. Connect the microphone cable to the microphone input in the GLM Adapter device.
5. Download the GLM software at the Genelec web site ([www.genelec.com](http://www.genelec.com)). Install the GLM software and follow the instructions in the software to measure and set up your monitors.
6. If you plan to not use a computer for controlling the monitors, use the GLM software to write the settings into the monitors (use menu item "Store | Store the Current Group Settings...").

The GLM network may also be used for monitor control - switching between sets of loudspeakers, solo, mute, invoking calibrated levels etc. - or settings can be permanently stored in all monitors for a static and predictable setup. If so, a computer is only needed for the setup.

If the network is disconnected, settings stored using the GLM software can be enabled by setting the DIP switch "Stored" to ON.

The CONTROL NETWORK RJ-45 connectors are used for the GLM network. These connectors are not Ethernet LAN compatible. Do not connect to an Ethernet LAN.

## Setup Without Using The GLM

When GLM is not available, you can still adjust the 8331A for placement in a room by using the DIP switches on the back of the monitor. Settings are more limited but nevertheless provide the fundamental equalizers to compensate for the acoustical effects of the listening room, input selections and input sensitivity. To use this method, ensure that the GLM management network is not connected and set the DIP switch "Stored" to its OFF position.

### Stand-Alone Control Functions

#### Bass Roll-Off Control

The Bass Roll-Off control attenuates the monitor's output near the cut-off frequency. Attenuation levels of -2 dB, -4 dB or -6 dB (both switches ON) can be selected by combining settings on one or more switches. This setting may be needed to control the bass level in spaces with strong low frequency reverberance.

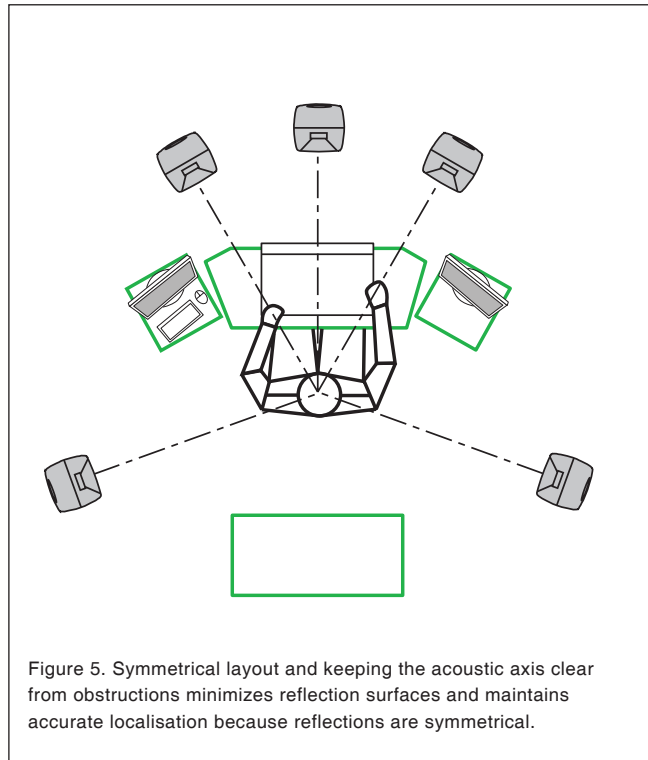

| Monitor Mounting Position           | Treble Tilt | Bass Tilt | Bass Roll-Off | Desktop |
|-------------------------------------|-------------|-----------|---------------|---------|
| Flat anechoic response              | None        | None      | None          | None    |
| Free standing in a damped room      | None        | -2 dB     | None          | None    |
| Free standing in a reverberant room | None        | -4 dB     | None          | None    |
| Near field on a reflective surface  | None        | -2 dB     | None          | -4 dB   |
| In a corner                         | None        | -4 dB     | -4 dB         | None    |

Table 1. Suggested Tone Control settings for some typical monitor placement positions.

#### Desktop Reflection Compensation

The desktop low frequency control attenuates the bass frequencies around 160 Hz by 4 dB. This feature is designed to compensate for the boost occurring often when the monitor is placed upon a meter bridge, table or similar reflective surface.

#### Bass Tilt Control

The Bass Tilt control switches offer three attenuation levels for the bass response below 800 Hz. The attenuation levels are -2 dB, -4 dB and -6 dB (both switches ON). This control is usually necessary when the monitors are placed near room boundaries such as at the wall or close to a room corner.

#### Treble Tilt Control

The Treble Tilt control allows adjusting the high frequency response above 5 kHz by +2 dB, -2 dB or -4 dB, which can be used for correcting an excessively bright or dull sounding system or to compensate for the high frequency level loss when the monitor is placed behind a screen.

#### LED Disable

This switch shuts off the front panel LED light.

| Colour                    | Indication  |
|---------------------------|---|
| Solid green               | Normal state, normal operation  |
| Blinking green            | GLM is adjusting the monitor  |
| Green blink every 10 sec. | Monitor is in an ISS power saving sleep state   |
| Red blink                 | Power amplifier overload protection is active (audio is modified because of protection) |
| Solid red                 | Monitor is muted  |
| Yellow                    | Monitor is not in the active (playing) group  |
| Yellow blinking           | Overheat protection is active (audio is modified because of protection)                 |

Table 2. Monitor front panel light indications summary

## ISS

This switch activates or deactivates the ISS automatic power saving function. The default time for ISS activation is 60 minutes, but the time can be adjusted in the GLM software.

## Digital

The Digital switch selects the digital audio channels on the AES/EBU. Turning both switches on reproduces the sum of the A and B channels. When both channels are selected 6 dB of attenuation is applied to avoid overloading the monitor.

## Level

The Level switches reduce the monitor output in 10 dB steps (-10 dB, -20 dB and with both switches set to ON, -30 dB). The effects of these switches combine with the effect of the rotary level adjustment control. The total setting range is 42 dB.

## Stored

The Stored switch selects between the application of the above listed controls on the monitor's back panel and applying the settings stored inside the monitor memory using the GLM calibration software. Setting the Stored switch to the OFF position selects the settings defined by the monitor's controls. Setting the Stored switch to ON position selects the use of internally stored GLM settings. When the Stored switch is set to the ON position the adjustments on the monitor have no effect.

## Operating Environment

This product is designed for indoor use only. The permissible ambient temperature is 15-35 degrees Celsius (50-95°F) and relative humidity 20% to 80% (non-condensing). To prevent condensation of humidity, after the product has been stored or transported in a cool environment and is then taken into a warm room, wait 0.5-1 hours before opening the packaging and connecting to the mains power.

Sufficient cooling around the 8331A must be ensured. The minimum clearance behind, above and on both sides of the monitor is 50 mm (2 in). If the product is installed in a recess, the space must be ventilated sufficiently to dissipate the heat.

## Mounting And Placing Monitors

### Mounting Options

The vibration insulating Isolation Positioner/Decoupler™ (Iso-Pod™) table stand allows tilting of the monitor. The stand spring can be attached to three mounting points on the 8331A enclosure, allowing the Iso-Pod to be used in vertical or horizontal positions.

Aim the monitor so that its acoustic axis points towards the listening position (see Figure 4). Place the monitors symmetrically at equal distances from the listening position. If possible, place the listening position on the left-right centerline of the room (see Figure 5). When a monitor is placed far away (1.0-2.2 m, 3-7 ft) from the acoustically hard wall behind the monitor, an acoustic reflection from the wall may cause cancellation of low frequencies and reduce the bass output.

Minimize reflections by placing the monitors away from acoustically reflective surfaces. Acoustic reflections from objects like desks, cabinets and computer monitors can cause unwanted coloration and blurring of the sound image. Putting the monitors on stands behind and above a mixing console usually improves the response over placing monitors on a meter bridge. Symmetrical positioning of the sound reflecting objects maintains a balanced soundstage (see Figure 5).

A wide variety of ceiling and wall mounts are available through your Genelec dealer. Genelec 8331A can be fitted with König & Meyer monitor mounts using two M6 x 10 mm threaded holes on the enclosure back. There is also a 3/8 in UNC threaded hole in the base of the monitor. Consult the Genelec Accessories Catalogue at [www.genelec.com](http://www.genelec.com) or your local distributor/dealer for information.

### Front Panel Light

Normally, the light on the front panel is green, indicating normal operational mode. Red and yellow colours are used to indicate special situations. See Table 2.

### Use With Subwoofers

In situations requiring deeper fundamental response or multichannel bass management, Genelec recommends using the 7300 series subwoofers. For more detailed system configuration and matching products, please consult the on-line Genelec Product Selection Tool at [www.genelec.com](http://www.genelec.com).

### Maintenance

There are no user serviceable parts inside the monitor. Maintenance or repair must only be done by Genelec certified service personnel. The monitor enclosure must not be opened. Opening the monitor may lead to loss of the individual monitor factory calibration and damage to components.

### Safety Considerations

Although the 8331A has been designed in accordance with international safety standards, to ensure safe operation and to maintain the monitor under safe operating conditions, the following warnings and precautions must be observed:

- Servicing and adjustment must only be performed by certified Genelec service personnel. The monitor enclosure must not be opened.
- Do not use this product with an unearthed mains cable

or a mains connection without the protective earth contact as this may lead to personal injury.

- To prevent fire or electric shock, do not expose the unit to water or moisture.
- Do not place any objects filled with liquid, such as vases on the monitor or near it.
- Note that the amplifier is not completely disconnected from the AC mains service unless the mains power cord is removed from the monitor loudspeaker or the mains outlet.
- Free flow of air behind and around the monitor is necessary to maintain sufficient cooling. Do not obstruct airflow around the monitor.

**WARNING!**

The 8331A is capable of producing sound pressure levels in excess of 85 dB, which may cause hearing damage. Sound exposure level integrated over an 8 hour working day should be limited to 80 dB(A) to reduce the risk of permanent hearing damage. For each 3 dB increase in sound exposure, half the exposure time should be observed (equal energy).

**Guarantee**

The Genelec 8331A is guaranteed for two years against manufacturing faults or defects altering performance. Refer to the reseller for full sales and guarantee terms.

**Compliance To FCC Rules**

Note: This equipment has been tested and found to comply with the limits for a Class B digital device, pursuant to part 15 of the FCC Rules. These limits are designed to provide reasonable protection against harmful interference in a residential installation. This equipment generates, uses and can radiate radio frequency energy and, if not installed and used in accordance with the instructions, may cause harmful interference to radio communications. However, there is no guarantee that interference will not occur in a particular installation. If this equipment does cause harmful interference to radio or television reception, which can be determined by turning the equipment off and on, the user is encouraged to try to correct the interference by one or more of the following measures:

- Reorient or relocate the receiving antenna.
- Increase the separation between the equipment and receiver.
- Connect the equipment into an outlet on a circuit different from that to which the receiver is connected.
- Consult the dealer or an experienced radio/TV technician for help.

Modifications not expressly approved by the manufacturer could void the user's authority to operate the equipment under FCC rules.

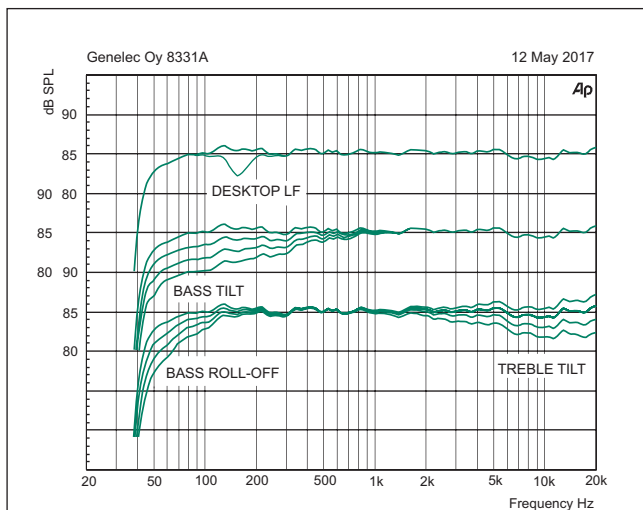

Figure 6. The curves above show the effect of the "Bass Tilt", "Treble Tilt", "Desktop Low Frequency" and "Bass Roll-Off" controls on the free field response of the 8331A.

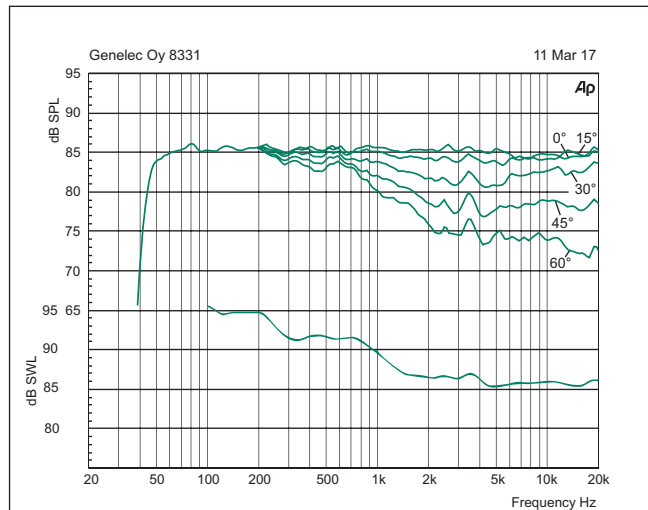

Figure 7. Frequency responses at 0, 15, 30, 45 and 60 degree angles and power response in full space. Input level -20 dBu.

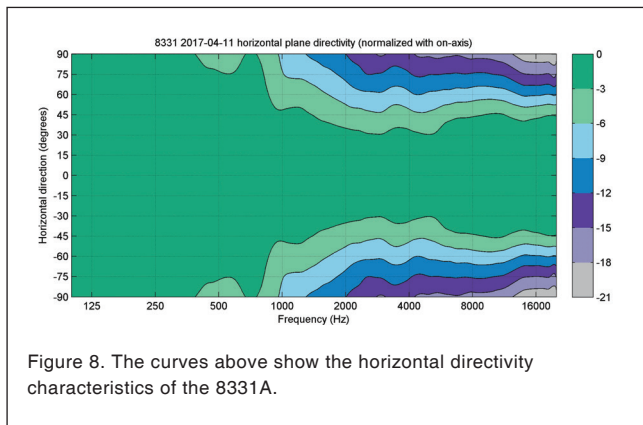

Figure 8. The curves above show the horizontal directivity characteristics of the 8331A.

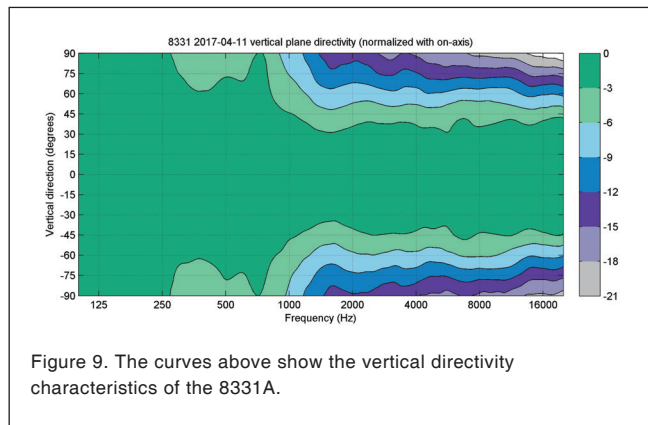

Figure 9. The curves above show the vertical directivity characteristics of the 8331A.

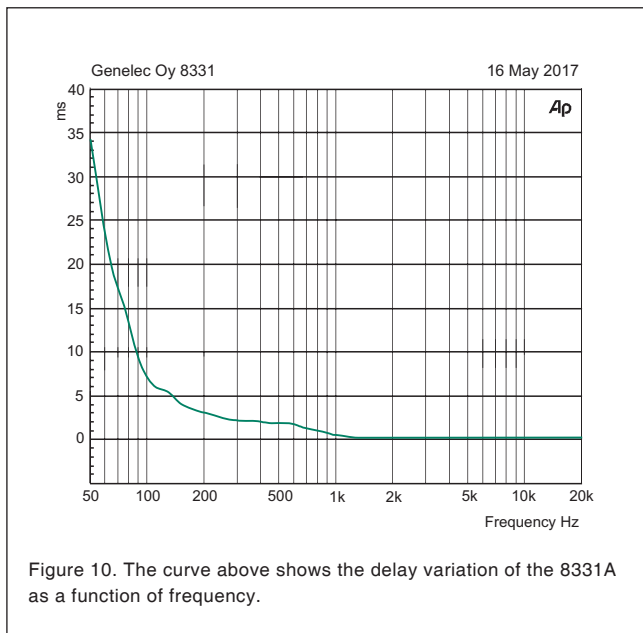

Figure 10. The curve above shows the delay variation of the 8331A as a function of frequency.

**SYSTEM SPECIFICATIONS**

|  |  |
|--|--|
| Lower cut-off frequency, -6 dB   | < 45 Hz  |
| Upper cut-off frequency, -6 dB   | > 37 kHz   |
| Accuracy of frequency response, ± 1.5 dB   | 58 Hz – 20 kHz   |
| Maximum short term sine wave acoustic output on axis in half space, averaged from 100 Hz to 3 kHz at 1 m                           | ≥ 104 dB SPL   |
| Maximum long term RMS acoustic output in the same conditions with IEC weighted noise (limited by driver protection circuit) at 1 m | 99 dB SPL  |
| Maximum peak acoustic output per pair in a listening room with music material at 1 m   | 110 dB   |
| Self generated noise level in free space at 1 m on axis (A-weighted)   | ≤ 0 dB   |
| Harmonic distortion at 85 dB SPL at 1 m on axis<br>Freq: 50...100 Hz<br>> 100 Hz   | < 2 %<br>< 0.5 %   |
| Drivers<br>Bass<br>Midrange<br>Treble  | Dual 130 x 65 mm (5 <sup>1</sup> / <sub>8</sub> x 2 <sup>5</sup> / <sub>8</sub> in) oval cones<br>90 mm (3 <sup>1</sup> / <sub>2</sub> in) cone (coaxial)<br>19 mm (3 <sup>3</sup> / <sub>4</sub> in) metal dome (coaxial) |
| Weight   | 6.7 kg (15 lb)   |
| Dimensions<br>Height including IsoPod stand<br>Height without IsoPod<br>Width<br>Depth   | 305 mm (12 in)<br>285 mm (11 <sup>1</sup> / <sub>4</sub> in)<br>189 mm (7 <sup>1</sup> / <sub>2</sub> in)<br>212 mm (8 <sup>3</sup> / <sub>8</sub> in)   |

**AMPLIFIER SECTION**

|  |                        |
|--|------------------------|
| Bass amplifier short term output power   | 72 W                   |
| Midrange amplifier short term output power   | 36 W                   |
| Treble amplifier short term output power<br>(Long term output power is limited by driver protection circuitry) | 36 W                   |
| Amplifier system THD at nominal output   | <0.05%                 |
| Mains voltage  | 100-240 VAC 50/60 Hz   |
| Power consumption<br>ISS active<br>Idle<br>Full output (short term)  | < 0.5 W<br>4 W<br>60 W |

**SIGNAL PROCESSING**

|   | <b>8331A</b>   |
|---|--|
| Analog signal input connector XLR female, balanced 10 kOhm  | pin 1 gnd<br>pin 2 non-inverting<br>pin 3 inverting  |
| Maximum analog input signal<br>Analog input sensitivity (100 dB SPL at 1 m)<br>Analog input sensitivity control                         | +24.0 dBu<br>-6 dBu<br>Adjustable from +36 to -6 dBu |
| Digital signal input connector XLR female 110 Ohm<br>Digital signal output / Thru connector XLR male 110 Ohm                            | AES/EBU Single Wire<br>AES/EBU Single Wire           |
| Digital audio input<br>Word length<br>Sample rate<br>Digital input sensitivity (100 dB SPL at 1 m)<br>Digital input maximum attenuation | 16 - 24 bits<br>32 - 192 kHz<br>-30 dBFS<br>42 dB    |
| Control network<br>Type<br>Connection   | Proprietary GLM™ network<br>2 RJ45, CAT5 cables      |
| Crossover frequencies<br>Bass/Mid<br>Mid/Treble   | 500 Hz<br>3 kHz                                      |
| GLM™ software frequency response adjustment*<br>Parametric notch filters<br>Shelving filters  | 16<br>2 LF and 2 HF                                  |
| System room response calibration  | Genelec GLM AutoCal™, GLM™ manual, Stand-alone*      |

\* The notch and shelving filters adjustments, AutoCal™ and GLM™ manual system calibration features are part of the Genelec Loudspeaker Manager (GLM™) software



## 介绍

感谢您选择真力产品！为人们提供最精准的声音再现，是真力自1978年成立以来的不懈追求。如今，世界上已经有超过一百万只真力监听音箱——欢迎加入我们！

每一只真力监听音箱，都在位于芬兰伊萨尔米的工厂设计、手工制作与严格检测。我们的监听音箱设计使用寿命长达数十年，在整个产品周期中，我们不遗余力地为客户提供产品与技术的维护和支持。

请扫描音箱包装上的二维码，注册您的音箱。注册之后，您将获得长达5年的硬件质量保修。

更多信息请参考：[https://www.genelec.cn/?page\\_id=17021](https://www.genelec.cn/?page_id=17021)

## 系统特征

每只8331A配备1条电源线，1条5米GLM网线以及这本说明书。

真力8331A适用高精度、高可靠性要求的专业监听场合。它集成了真力多项核心技术，以开创性的同轴设计配合大面积指向性控制波导，得到了点声源重放的精准声像定位，扩大了最佳聆听区域。

## GLM™ (真力音箱管理) 软件和 GLM测试套件

使用GLM音箱管理软件可以发挥8331A的最大性能，使音箱与房间环境精确耦合。您可以在[https://www.genelec.cn/?post\\_type=products&page\\_id=24634](https://www.genelec.cn/?post_type=products&page_id=24634)

免费下载GLM软件。您可以定期访问以获得最新版本，并使用最新功能，或考虑使用基于云端的GLM版本。GLM测试套件包含GLM适配器和校准话筒，以便搭建、测试及控制GLM系统。GLM套件可在真力授权经销商处购买。

## MDC™最小衍射同轴单元

MDC™最小衍射同轴单元集成了高声压级中频单元和延伸至超声波频段的高频单元。这一独特设计解决了传统同轴单元设计难以避免的声波衍射问题，在声轴上和离轴方向都能得到平直的频率响应。

8331A既可以垂直摆放也可以横置摆放，适合于近场监听使用，让房间声学的影响降到最低。典型的聆听距离在1米至3米之间，取决于房间尺寸以及声压级要求。

## DCW™声波指向性控制波导

8331A具有超越常规尺寸的大型指向性控制波导，延伸至整个前面板。中频单元的盆体同时构成了高频指向性波导的一部分。在波导的上下两端内，藏有两个低频单元，通过面板上下的开口辐射低频。这一独特设计，可以使指向性受控的频段扩展至低频。

## ACW™声学隐蔽式低频单元

一对低频单元隐藏于8331A的前面板后，与中频单元、高频单元构成声学中心重合的三分频同轴结构。实现了理想的点声源辐射。

## SAM™智能有源监听技术

真力SAM智能有源监听技术可以提升监听的可靠性和精确性。智能有源监听音箱具备多组参量均衡设置，可以利用GLM真力音箱管理软件进行自动校准设定，精确补偿房间声学带来的染色。得益于此，真力SAM音箱可在各种声学环境中获得自然的响应和精确的声像定位。

## 音频输入

8331A支持平衡线路模拟输入和AES/EBU格式数字输入，可以方便接入到各种专业音频制作环境中。最大的模拟输入电平为+25dBu (13.7Vrms或19.5V峰值)。在灵敏度设置为最高的情况下，当模拟输入信号为-6dBu时，可在自由场中距离音箱1米处得到100dB SPL的声压级。当数字输入信号电平为-30 dBFS时，可在自由场中距离音箱1米处得到100dB SPL的声压级。请注意，0 dBFS代表最大的数字输入电平。

该XLR音频输入接口可以支持AES/EBU格式数字输入和线路模拟输入。当AES/EBU数字输入电平极低时，输入源可能无法自动切换。此时，可以通过GLM软件切换输入源。

在使用电平可调的数字音源时，更优的方式为使用音箱背板的音量旋钮进行衰减，而非降低音源的音量。这样音源可以利用更高的电平输出以获得更高数字精度，同时完整利用8331A惊人的低底噪，获得更高的动态范围。

AES/EBU输入使用一条信号线传送两声道信号。数字输入信号将被直接复制至音箱背面的DIGITAL OUT (数字输出) 卡侬公接口输出。利用此功能，可使用菊花链的方式最多将4只音箱串接使用，使用DIP开关或GLM软件设定每只音箱的信号通道。

## 电源管理

8331A电源输入支持全球通用电压 (100-240VAC, 50-60 Hz)。它可以在世界上任意国家或地区使用，在不同电压环境中都可以获得最大输出。如使用发电机、逆变器或低品质UPS等设备供电，我们建议使用额外设备来滤除电源杂波。

ISS™智能休眠功能可在无信号输入时让音箱自动进入休眠模式，此时设备能耗将降低至1瓦以下。在检测到输入信号后，音箱将自动回到工作状态。进入休眠的等待时间可通过GLM软件设置。当ISS功能启用后，您不再需要手动开启音箱，随时可以让音箱进入工作状态。使用DIP开关开启ISS功能后，默认的等待时间为60分钟。

## 使用GLM进行音箱设置

尽管8331A可以脱离GLM软件进行使用，但仅有在使用PC或Mac电脑运行的GLM软件进行设置的情况下，才能发挥出最佳性能。



图1 GLM控制网络连接示意图



图2 8331A背板的接口与控制按钮

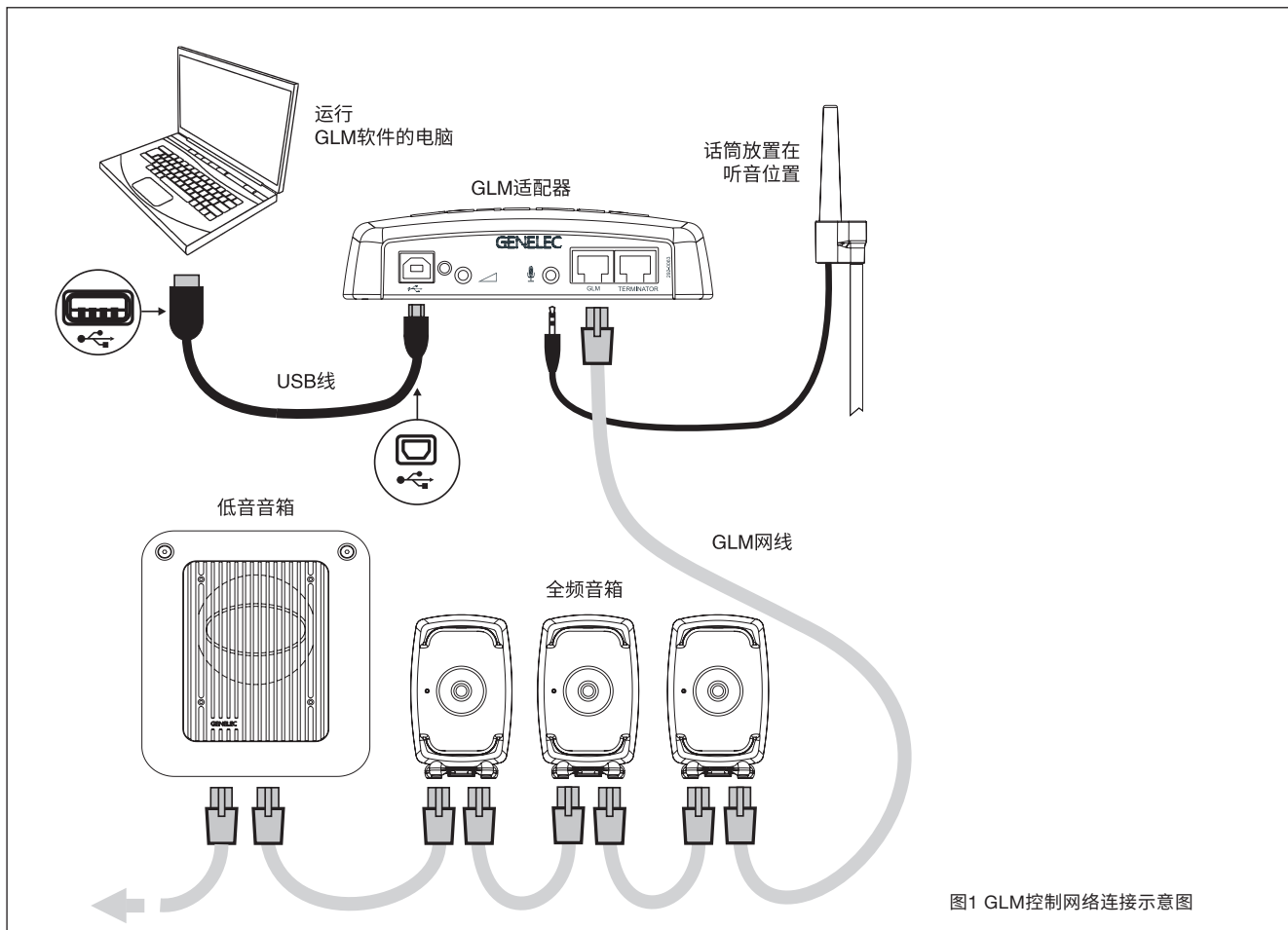

图3 接口面板详图

因此，真力建议使用GLM软件设置8331A和其他SAM音箱。您可以在《GLM系统使用手册》中获得关于GLM使用的详细描述。

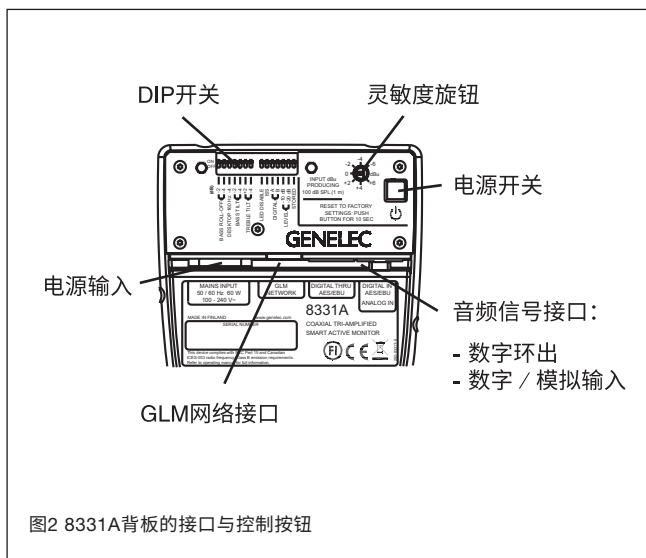
GLM软件和真力音箱控制网络提供了自动化的系统设置与房间均衡校正，适用于从单声道到3D沉浸式音频的制作系统，以及使用一只或多只低音音箱的情况。GLM的核心是AutoCal自动校正算法，该算法基于数千个专业听音室的真实数据研发而成。

GLM测试套件的使用包括以下步骤：

1, 使用5类网线 (RJ45接头) 将每只音箱 (包括低音音箱) 串接起

来，最终连接到GLM适配器的网络输入接口 (见图1)；

2, 将GLM适配器通过USB线连接到电脑；

3, 使用话筒支架，将真力校准话筒置于听音位置。校准话筒朝上，话筒顶部与听音者耳朵齐平。GLM测试套件中已包含校准话筒。

4, 将话筒连接到GLM适配器的话筒输入接口；

5, 从真力官方网站 ([https://www.genelec.cn/?post\\_type=products&page\\_id=24634](https://www.genelec.cn/?post_type=products&page_id=24634)) 下载最新的GLM软件，安装软件并根据提示进行音箱设置和校准；

6, 如果您不需要随时在电脑上运行GLM软件控制音箱，可以将GLM软件设置存储到音箱中 (利用菜单选项中的“Group (编组) | Store Group Settings (保存当前编组设置) ...”)

GLM网络还可以用于监听控制——多组音箱之间切换，独听

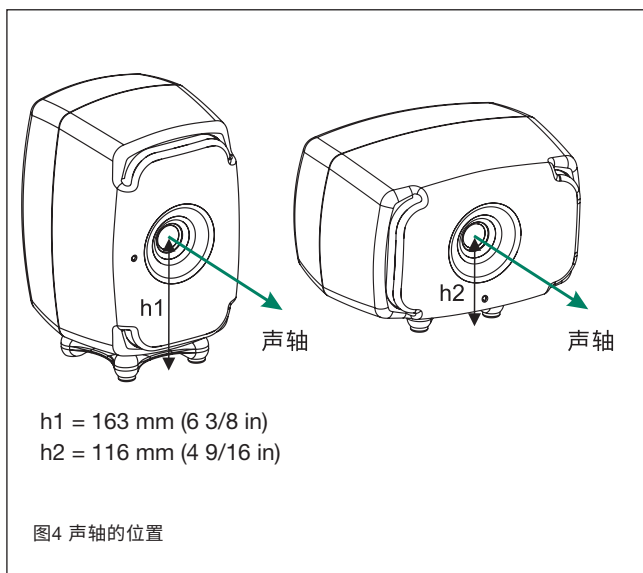

(Solo), 静音 (Mute), 调用响度校准预设等。如果音箱的摆放位置和使用功能固定不变时, 可以将设置永久存储到音箱中。在这种情况下, 仅在测试时需要使用电脑。

如果GLM网络断开, 将DIP开关“Store”调至ON状态可以启用保存在音箱内的设置。GLM控制网络接口 (RJ45网线接口) 不配有有线局域网 (Ethernet LAN)。请勿将其连接到路由器、交换机等局域网设备。

## 脱离GLM进行音箱设置

当脱离GLM时, 您仍可以使用音箱背面的DIP开关来调整8331A的设置。此时设置功能相对有限, 仅能有限地提供输入选择、灵敏度调整, 以及基础的房间声学补偿设置。如需使用此模式, 请确保GLM网络断开, 同时将“Stored” DIP开关调至OFF状态。

### 单机控制功能

#### 低频滚降 (Bass Roll-Off) 控制

低频滚降 (Bass Roll-Off control) 可以衰减低频截止点附近的低频。使用一个或多个低频滚降DIP开关, 可以获得-2dB、-4dB以及-6dB (两个开关均设为ON) 的衰减。在低频混响较强的环境中, 可能需要启用此设置。

#### 桌面反射补偿 (Desktop)

桌面反射补偿将在160Hz左右的低频频率衰减4dB。当音箱放置在调音台表桥、桌面或类似反射面上时, 使用该设置可以补偿这种摆位带来的低频隆起。

#### 低频搁架 (Bass Tilt) 控制

低频搁架 (Bass Tilt) 为800Hz以下的低频响应提供三种衰减设置: -2dB、-4dB以及-6dB (两个开关均设为ON)。通常当音箱靠近房间边界时, 如靠近墙或靠近角落, 需要启用此设置。

#### 高频搁架 (Treble Tilt) 控制

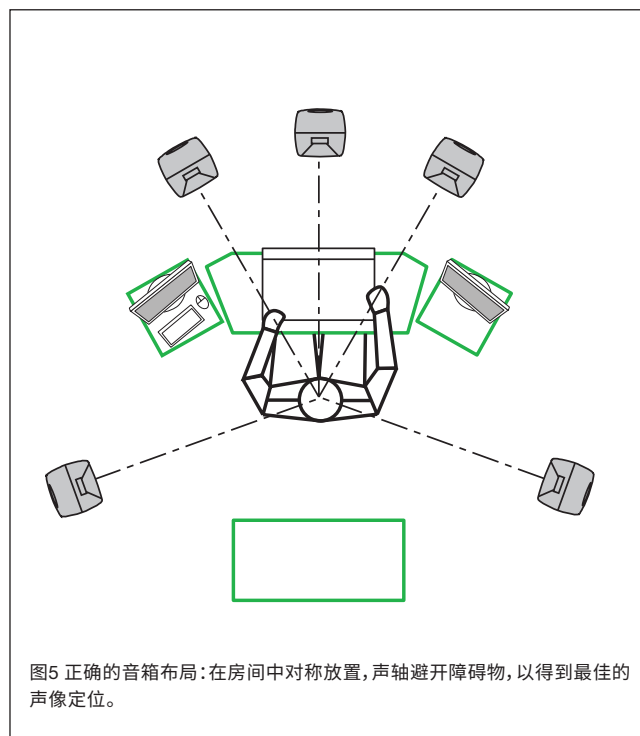

| 音箱安装摆位         | 高频搁架控制 | 低频搁架控制 | 低频滚降控制 | 桌面反射补偿 |
|----------------|--------|--------|--------|--------|
| 消声室放置          | 关闭     | 关闭     | 关闭     | 关闭     |
| 在吸声室自由放置       | 关闭     | -2 dB  | 关闭     | 关闭     |
| 在混响室自由放置       | 关闭     | -4 dB  | 关闭     | 关闭     |
| 放在反射面上, 用于近场监听 | 关闭     | -2 dB  | 关闭     | -4 dB  |
| 靠角落放置          | 关闭     | -4 dB  | -4 dB  | 关闭     |

表1 在不同声学环境下的建议音色调节设置

高频搁架 (Treble Tilt control) 为5kHz以上的高频提供+2dB、-2dB和-4dB三种设置。当音响系统的高频过分明亮或暗淡时, 或者音箱置于透声幕后导致高频衰减时, 需要启用此设置进行补偿。

#### 关闭LED

此拨挡开关可以关闭前面板的LED指示灯。

#### ISS智能休眠

此拨挡开关用于开启或关闭ISS自动休眠功能。默认休眠等待时间为60分钟, 该时间可在GLM软件中设置。

#### 数字

数字拨挡开关可以设定音箱重放的AES/EBU通道。将两个开关都调至ON时, 将混合A和B通道信号进行重放, 此时音箱会衰减6dB以防信号过载。

#### 电平

电平拨挡开关可以以10dB步进衰减音箱的输出 (-10dB、-20dB或两个拨挡开关都打开为-30dB)。此设定与灵敏度旋钮可同时叠加使用, 最大调整幅度为42dB。

| 颜色         | 状态                       |
|------------|--------------------------|
| 绿色长亮       | 正常工作状态                   |
| 绿色闪烁       | GLM正在调整该音箱               |
| 绿色每10秒闪烁一次 | 音箱处于休眠状态                 |
| 红色闪烁       | 功放过载保护启动<br>(音频信号因此受到改变) |
| 红色长亮       | 音箱哑音                     |
| 黄色         | 音箱未在当前编组                 |
| 黄色闪烁       | 过热保护启动<br>(音频信号因此受到改变)   |

表2 音箱前面板LED指示灯定义

## 存储

存储的拨挡开关 (Stored) 可以切换上文提到的拨挡开关设置与 GLM 校准后存储在音箱内部的设置。当拨挡开关为 OFF 时, 音箱状态将以音箱背板的手动设置为准; 当调整为 ON 时, 将调取音箱内部存储的 GLM 设置, 此状态下音箱背板的手动设置功能将失效。

## 使用环境

此产品仅限室内使用。允许的环境温度为 15-35 摄氏度 (50-95 华氏度), 相对湿度为 20% 至 80% (未凝结)。为了防止冷凝, 当此产品从温度较低的储存或运输环境, 转移至温暖的环境中时, 请静候 0.5 到 1 小时后再开箱使用。另必须保证 8331A 周围有足够的冷却散热空间。音箱后方、上方以及侧方需留有最小 50 毫米 (2 英寸) 的净空。如果音箱采用嵌入式安装, 需保证有效的通风以供散热。

## 音箱的安装和摆放

### 安装选项

Iso-Pod™ 桌面隔震音箱垫可以调节音箱的俯仰角度。音箱垫的导轨可以安装于音箱背板的三个不同安装点, 实现水平和垂直摆放。

音箱的声轴需指向听音位置 (见图4)。将音箱对称摆放, 确保每只音箱与听音位置等距。如果可能, 将听音位置设置在房间左右的中轴线上 (见图5)。当音箱距离其后方的实墙 1.0-2.2 米时, 墙面的反射会造成低频的抵消, 减少低音输出。

将音箱远离声学反射面放置以减弱反射声的影响。桌面、柜体、电脑显示器等带来的反射声会造成不良的声染色以及声像定位模糊。将音箱用支架放置在调音台后上方, 通常会比放置在调音台表桥上更理想。另将声反射物体对称摆放, 可以获得平衡的声像定位 (见图5)。

您可以从真力经销商处选购多种吊顶与挂墙安装配件。真力 8331A 可通过背板的两个 M6 x 10 毫米螺纹孔适配 König & Meyer 音箱挂架。另外音箱底部有一个 3/8 英寸粗牙螺纹孔。可通过真力网站 [www.genelec.com](http://www.genelec.com) 查阅《真力配件目录 (Genelec Accesories Catalogue)》获取更多信息。

## 前面板指示灯

通常, 前面板指示灯为绿色, 表示音箱正在正常工作状态。当音箱处于特殊状态时, 指示灯会变为红色或黄色。详情请见表2。

## 配合低音音箱使用

如果您需要重放更低的频率, 或需要多声道低频管理, 真力建议您选择 7300 系列低音音箱。更多有关系统设置与搭配的信息, 请参照真力官网 [www.genelec.com](http://www.genelec.com) 中的“产品选择工具 (Genelec Product Selection Tool)”。

## 维护

在音箱内部没有任何用户可调整的部分。任何关于音箱的维护或维修都应由真力授权的维修服务人员来完成。切勿拆开音箱箱体。拆开音箱箱体可能导致出厂校正失效以及元件受损。

## 安全注意事项

8331A 严格按照国际安全标准设计, 但您仍需注意以下警告和注意事项, 确保安全操作以及安全的音箱维护环境:

- 切勿自行拆开音箱。任何关于音箱的维护或维修都应由真力授权的维修服务人员来完成。
- 切勿使用未连接保护地的电源, 这可能会危及人身安全。
- 切勿将音箱暴露在水中或潮湿环境, 这可能会导致火灾或触电。
- 切勿在音箱上或其附近摆放装有液体的物品, 例如花瓶。
- 请注意, 本设备采用电源插头作为断开装置。除非将电源线从音箱上或电源插座上拔掉, 否则功放并未完全与交流电源断开连接。
- 切勿阻挡音箱周围的气流。确保音箱后方有足够的空气流动, 使音箱能够充分冷却。

### 警告!

8331A 可以产生超过 85dB 的声压级, 这可能会引起永久性听力损伤。若聆听时间超过 8 小时/天, 请将声压级控制在 80dB (A 计权) 以内以降低永久听力损伤的风险。声压级每增加 3dB, 聆听时间应当减半。

## 质保

真力 8331A 针对材料和工艺上的质量问题提供 2 年的质保服务。通过注册您的音箱, 可将质保服务延长至 5 年。详细质保条款请您咨询当地经销商。

## FCC 符合性声明

注意: 该设备已经过测试, 符合 B 类数字设备的限制, 且符合 FCC 标准第 15 部分的要求。这些限制旨在提供合理的保护, 防止在住宅区安装时产生有害干扰。该设备会产生, 使用并辐射射频能量, 如果未按照说明安装和使用, 则可能对无线通信造成有害干扰。但是, 我们无法保证在特定安装中不产生干扰。如果设备对无线电和电视的接收产生有害的干扰, 用户可通过开关该设备进行验证, 我们建议用户采用下述一种或多种手段进行消除干扰:

- 重新调整天线的方向和位置。
- 增加该设备与接收器之间的距离。
- 将该设备和接收器分别连接到不同电路的插座上。

- 向经销商或有经验的无线电/电视技术人员寻求帮助。

任何未经制造商许可的改动都将让用户丧失在FCC规定下操作设备的权力。



图6 以上曲线是在自由声场中对 8331A 分别使用了低频搁架控制 (Bass Tilt), 高频搁架控制 (Treble Tilt), 桌面反射补偿 (Desktop) 和低频滚降控制 (Bass Roll-Off) 后的频率响应曲线。



图7 以上曲线是当输入电平为-20dBu时, 在自由声场中偏离声轴不同角度 (0°、15°、30°、45°和60°) 测得8331A的频率响应曲线。

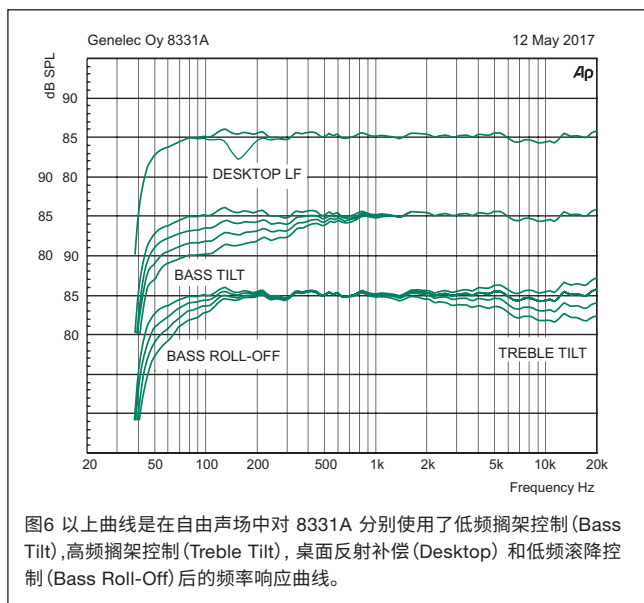

图8 上图表示8331A的水平面指向特性。

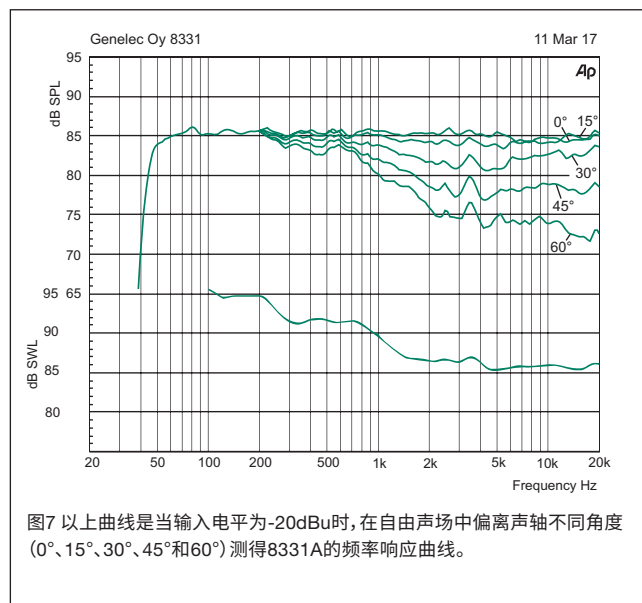

图9 上图表示8331A的垂直面指向特性。

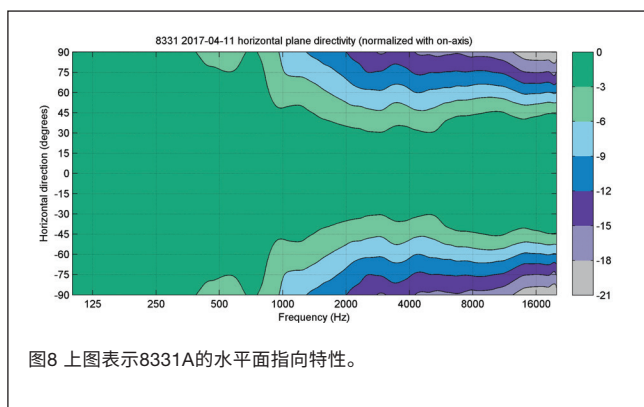

图10 以上曲线表示不同频率下8331A的延时响应变化。

**系统参数**

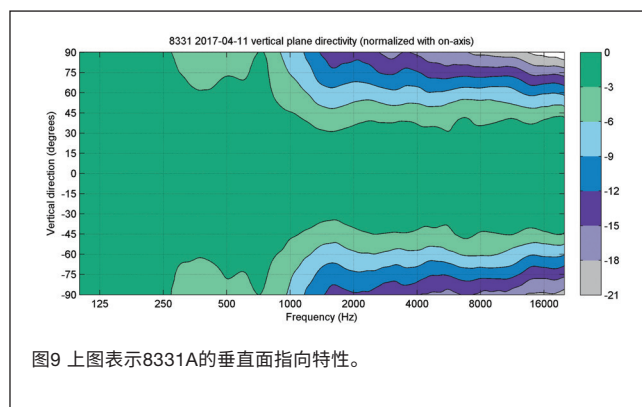
|  |  |
|--|--|
| 低频截止频率   | < 45 Hz  |
| 高频截止频率   | > 37 kHz   |
| 频率响应精确度  | 58 Hz – 20 kHz   |
| 半开放空间内, 轴上最大短时正弦波声学输出, 100 Hz - 3 kHz均值 @1米                | ≥ 104 dB SPL   |
| 在相同条件下, 使用IEC计权噪声测试最大长期RMS声学输出 (受驱动单元保护电路限制) @1米           | 99 dB SPL  |
| 在听音室内, 使用音乐素材进行测试, 在距音箱1米处每对音箱最大峰值声学输出。                    | 110 dB   |
| 自由场内自身噪声电平 @ 1米 轴上 (A计权)                                   | ≤ 0 dB   |
| 总谐波失真 @85 dB SPL @1米, 轴上。<br>频率: 50...100 Hz<br>> 100 Hz   | < 2 %<br>< 0.5 %   |
| 驱动单元<br>低音<br>中音<br>高音                                     | 双130 x 65 毫米(5 1/8 x 2 5/8 英寸)圆锥锥体<br>90 毫米 (3 1/2 英寸) 锥体 (同轴)<br>19 毫米 (3/4 英寸) 金属球顶 (同轴) |
| 重量   | 6.7千克 (15磅)  |
| 尺寸:<br>高度 (含Iso-Pod防震底座)<br>高度 (不含Iso-Pod防震底座)<br>宽度<br>深度 | 305毫米 (12英寸)<br>285毫米 (11 1/4 英寸)<br>189毫米 (7 1/2 英寸)<br>212毫米 (8 3/8 英寸)                  |

**功放部分**

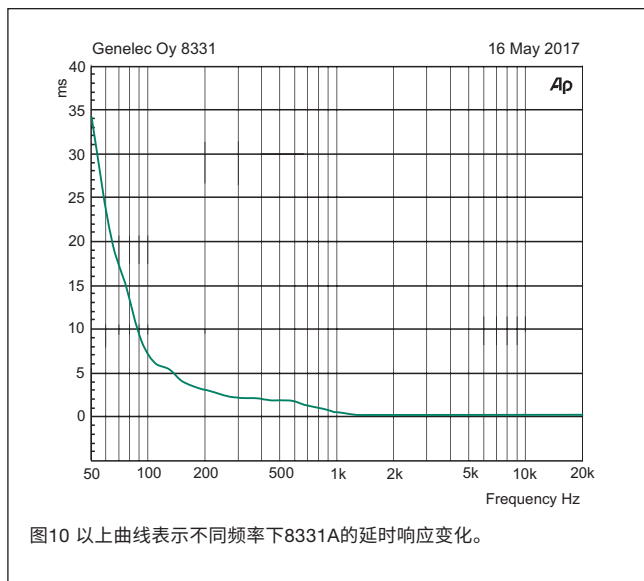
|   |                        |
|---|------------------------|
| 低音功放短期输出功率<br>中音功放短期输出功率<br>高音功放短期输出功率<br>(长期输出功率受驱动单元保护电路限制) | 72 瓦<br>36 瓦<br>36 瓦   |
| 在标称输出功率下功放系统失真参数  | <0.05%                 |
| 电源电压  | 100-240 VAC 50/60 Hz   |
| 功耗<br>待机<br>空闲<br>满输出 (短期)                                    | < 0.5 瓦<br>4 瓦<br>60 瓦 |

**信号处理**

|   |   |
|---|---|
|   | <b>8331A</b>                                      |
| 模拟信号输入接口: XLR母座 (平衡式10k欧姆)  | 针脚1: 地<br>针脚2: 正极<br>针脚3: 负极                      |
| 最大模拟信号输入电平<br>模拟输入灵敏度 (100 dB SPL 在 1 米处)<br>输入灵敏度控制                  | +25.0 dBu<br>-6 dBu<br>调整范围为从+36到-6dBu            |
| 数字信号输入接口: XLR母座 (110 欧)<br>D数字信号输出 / 环出接口: XLR公座 (110 欧)              | AES/EBU 单线<br>AES/EBU 单线                          |
| 数字信号输入<br>量化精度<br>采样范围<br>数字输入灵敏度 (100 dB SPL 在 1 米处)<br>数字信号输入最大衰减范围 | 16 - 24 bits<br>32 - 192 kHz<br>-30 dBFS<br>42 dB |
| 控制网络<br>类型<br>连接方式  | 专用的真力GLM网络<br>2条5类网线                              |
| 分频点<br>低频 / 中频<br>中频 / 高频   | 500 Hz<br>3 kHz                                   |
| GLM软件频率响应调整 *<br>参量陷波滤波器<br>搁架滤波器                                     | 16<br>2个低频、2个高频                                   |
| 系统房间响应自动校准  | 使用真力GLM管理套件进行自动或手动校准, 也可使用音箱背板的独立控制开关 (DIP开关) *   |

\* GLM™真力音箱管理软件包含陷波滤波器和搁架滤波器的调整, 自动校准和GLM手动系统校准功能。

# GENELEC®

International enquiries:  
Genelec, Olvitie 5  
FIN-74100, Iisalmi, Finland  
Phone +358 17 83881  
Fax +358 17 812 267  
Email [genelec@genelec.com](mailto:genelec@genelec.com)

In the U.S. please contact:  
Genelec, Inc., 7 Tech Circle  
Natick, MA 01760, USA  
Phone +1 508 652 0900  
Fax +1 508 652 0909  
Email [genelec.usa@genelec.com](mailto:genelec.usa@genelec.com)

In Sweden please contact:  
Genelec Sverige  
Ellipsvägen 10B  
P.O. Box 5521, S-141 05 Huddinge  
Phone +46 8 449 5220  
Fax +46 8 708 7071  
Email [info@genelec.com](mailto:info@genelec.com)

真力中国  
北京市朝阳区酒仙桥路10号  
恒通商务园 B33-101  
电话 400 700 1978  
微信 真力GENELEC  
微博 @真力GENELEC  
Email [genelec.china@genelec.com](mailto:genelec.china@genelec.com)